

## GENERAL INTRODUCTION

Stainless Steel is a highly durable material used in many qualified applications. Like all materials, its production and use affect the environment in many different ways. Assessing the overall environmental impact of products requires an integrated approach that considers the product over its entire life cycle — Life Cycle Assessment (LCA).

LCA has been welcomed by the stainless steel industry as a means to provide our customers with an accurate profile of stainless steel's environmental credentials. In addition, it serves as a valuable tool to assist stainless steel makers in their continuing drives to improve environmental performance even further. These include:

- Developments to optimise environmental performance in steel making processes,
- The production of modern stainless steels and components that support customers' developments of environmental solutions.

The International Stainless steel Forum (ISSF) has undertaken a commitment to provide the best possible information to the industry stakeholders in the area of life cycle assessment (LCA), delivering transparent and authoritative data on the production of stainless steel from its raw materials.

Raw material LCI data have been provided by ICDA, NI and IMOA, using the same methodology and standards.

### What is Life Cycle Assessment?

LCA is a tool to assist with the quantification and evaluation of environmental burdens and impacts associated with product systems and activities, from the extraction of raw materials in the earth to end-of-life and waste disposal. The tool is increasingly used by industries, governments, and environmental groups to assist with decision-making for environment-related strategies and materials selection.

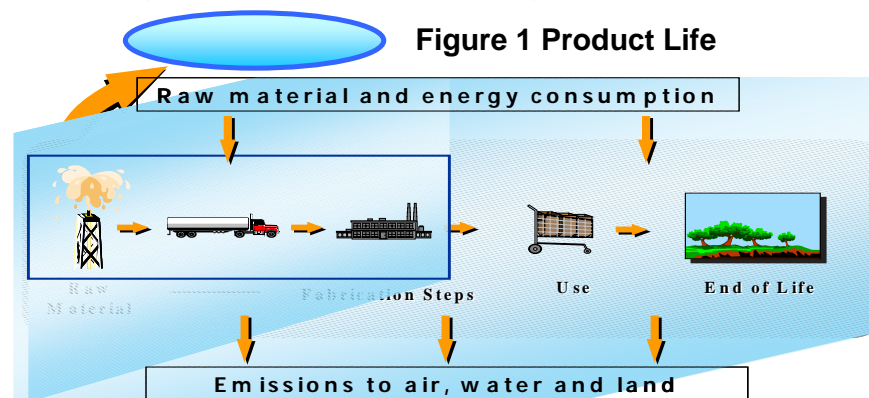

## What is Life Cycle Inventory?

Life Cycle Inventory (LCI) is one of the phases of a Life Cycle Assessment (LCA). LCI data quantify the material, energy and emissions associated with a functional system (for example, the manufacture of 1kg of hot rolled coil).

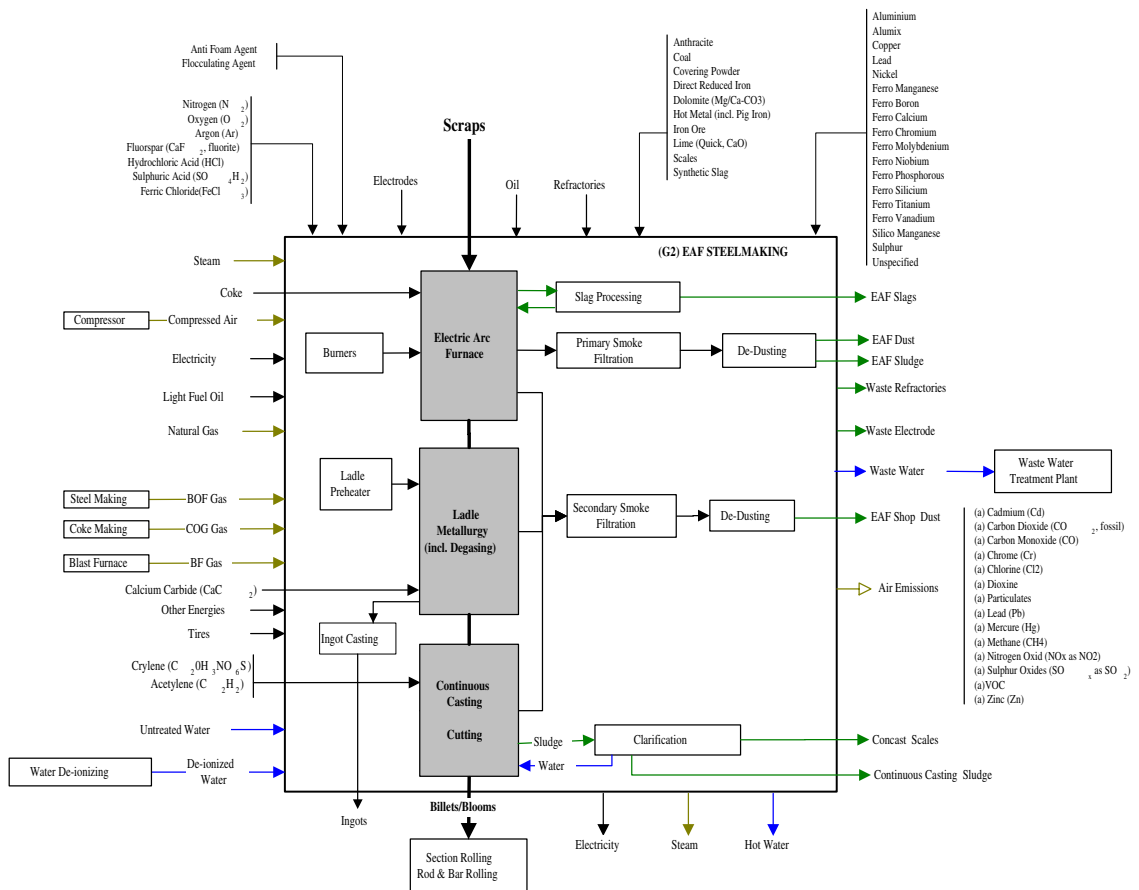

**Figure 2: LCI model of Electric Arc Furnace**

A full cradle-to-grave study looks at the production from raw material (cradle), through the use phase, and end-of-life (grave). The ISSF LCI was initially a cradle-to-gate study, where the analysis of data was from raw materials through to the stainless steel product at the works gate. After that ISSF developed a methodology for allocation of credits for recycling.

An example of the completeness of the inventory is illustrated in Figure 2, for the electric arc furnace. Such a model is used for every process stage required to make



stainless steel from its raw material extraction, through to the processing on the steel works.

The set of International Standards represented by ISO14040, outline the approach and rigor to which the exercise must adhere, including the necessity for independent third parties to critically review the work.

### **Global Life Cycle Inventory**

A global life cycle inventory (LCI) study has been carried out by ISSF to quantify resource use, energy and environmental emissions associated with the processing of eight stainless steel industry products, from the extraction of raw materials in the ground through to the steel factory gate. The eight products included in the study are the main stainless steel grades and finishes.(table 1) The products are of general relevance to a wide range of downstream applications including those in the construction and automotive etc...

The datasets involved in this study covers major stainless steel producers in Europe, Japan, Korea and USA with the focus on global averages for the production of austenitic, ferritic and duplex grades (flat products).

ISSF also developed a methodology for allocation of credits for recycling in order to assess accurate profiles of stainless steel products. The methodology is consistent with the ISO standard conforming methodology used by IISI for carbon steel. The LCI data with recycling credit were calculated by using LCI data both in case of production based on 100% virgin metal and in case of production based on 100% recycled scrap. LCI data both with recycling credit and without recycling credit are in the same table and can be compared. (see page 4)

In the methodology report (<http://www.worldstainless.org/About+stainless/Ss+and+he/LCI/>), it is demonstrated that stainless steel is a highly sustainable material and that the recycling ratio at end of life is a very significant factor when assessing the environmental profile of a metal like stainless steel.

**Table 1 Global LCI dataset**

Products
304 2B
304 BA
304 WHR
316 2B
409 2B
430 2B
430 BA
2205 2B



Figure 3 summarizes the input to the global LCI for stainless steel

World Stainless Steel LCI		Date of issue: 01/Dec/2005		
Inventory: Stainless_Steel_World_304_2B for 1000kg Product		Date of data: 1999-2004		
	Flow	Units	World(Mean) without credit	World(Mean) with credit
<b>Raw Material (in ground)</b>				
Inputs:	(r) Chromium (Cr, ore)	kg	xx.x	xx.x
	(r) Coal (in ground)	kg	xx.x	xx.x
	(r) Dolomite (CaCO3.MgCO3, in ground)	kg	xx.x	xx.x
	(r) Iron (Fe, ore)	kg	xx.x	xx.x
	(r) Lignite (in ground)	kg	xx.x	xx.x
	(r) Limestone (CaCO3, in ground)	kg	xx.x	xx.x
	(r) Manganese (Mn, ore)	kg	xx.x	xx.x
	(r) Molybdenum (Mo, ore)	kg	xx.x	xx.x
	(r) Natural Gas (in ground)	kg	xx.x	xx.x
	(r) Nickel (Ni, ore)	kg	xx.x	xx.x
	(r) Oil (in ground)	kg	xx.x	xx.x
<b>Scrap</b>				
	Stainless Steel Scrap (304, from external supply)	kg	xx.x	xx.x
	Stainless Steel Scrap (316, from external supply)	kg	xx.x	xx.x
	Stainless Steel Scrap (409, from external supply)	kg	xx.x	xx.x
	Stainless Steel Scrap (430, from external supply)	kg	xx.x	xx.x
	Steel Scrap (low alloy, from external supply)	kg	xx.x	xx.x
	Carbon Steel Scrap	kg	xx.x	xx.x
<b>Incoming Water (Volume)</b>				
	Water Used (direct cooling or process, total)	litre	xx.x	xx.x
	Water Used (total)	litre	xx.x	xx.x
Outputs:	<b>Air Emissions</b>			
	(a) Carbon Dioxide (CO2, fossil)	g	xx.x	xx.x
	(a) Carbon Monoxide (CO)	g	xx.x	xx.x
	(a) Chromium (Cr III, Cr VI)	g	xx.x	xx.x
	(a) Chromium (Cr VI)	g	xx.x	xx.x
	(a) Dioxins (unspecified)	g	xx.x	xx.x
	(a) Molybdenum (Mo)	g	xx.x	xx.x
	(a) Nickel (Ni)	g	xx.x	xx.x
	(a) Nitrogen Oxides (NOx as NO2)	g	xx.x	xx.x
	(a) Particulates (unspecified)	g	xx.x	xx.x
	(a) Sulphur Oxides (SOx as SO2)	g	xx.x	xx.x
<b>Water Emissions</b>				
	(w) Acids (H+)	g	xx.x	xx.x
	(w) Aluminium (Al3+)	g	xx.x	xx.x
	(w) Ammonia (NH4+, NH3, as N)	g	xx.x	xx.x
	(w) Cadmium (Cd++)	g	xx.x	xx.x
	(w) Chlorides (Cl-)	g	xx.x	xx.x
	(w) Chromium (Cr III, Cr VI)	g	xx.x	xx.x
	(w) Chromium (Cr VI)	g	xx.x	xx.x
	(w) COD (Chemical Oxygen Demand)	g	xx.x	xx.x
	(w) Copper (Cu+, Cu++)	g	xx.x	xx.x
	(w) Fluorides (F-)	g	xx.x	xx.x
	(w) Hydrocarbons (unspecified)	g	xx.x	xx.x
	(w) Iron (Fe++, Fe3+)	g	xx.x	xx.x

Example of datasheet Communicated to third parties Further details on the website [www.worldstainless.org](http://www.worldstainless.org)



## Conclusion

The stainless steel industry has carried out a comprehensive and rigorous LCI study based on the foundations for good practices for internal and external LCAs involving steel products.

ISSF also developed a methodology for allocation of credits for recycling in order to assess accurate profiles of stainless steel products. The methodology is consistent with the ISO standard conforming methodology used by IISI for carbon steel.

ISSF and Member Companies receive more and more requests for LCI data from customers and industry stakeholders. Data collected for the ISSF LCI study now enables the stainless steel industry to provide consistent LCI data for stainless steel products.

The ISSF Global LCI Study for Stainless Steel Products is one of the tools being used by the stainless steel industry to both improve the impacts of its own processes on the environment, and to work closely with its customers in improving the total impact of stainless steel-using products on the environment, over their complete life cycles.

If LCA is to be used as a serious tool for decision making, then it will require high standards of data, sound methodology and transparent reporting. The stainless steel industry has made a major step towards enhancement of these standards. ISSF intends to pursue improvement of the data quality with time. This will include further updates of the data and expanding the range of reliable data categories and developing factual end of life recycling ratios for stainless steel products.

International Stainless Steel Forum  
Brussels  
April 2006

The ISSF global LCI data for stainless steel products are available to LCA practitioners on request. If you would like further information, please use our online contact form (<http://www.worldstainless.org/About+stainless/Ss+and+he/LCI/LCI+Contact+Form.htm>).