

Cala Galdana Bridge

The Cala Galdana Bridge crosses the Algendar River in Menorca. There are panoramic views of this popular beach-side holiday resort from the 55 m span, 13 m wide road bridge. The main structure of the bridge is entirely stainless steel and includes two parallel arches, two longitudinal beams and transverse beams supporting the deck. Reinforced concrete makes up the abutments at each end, which sit on piled foundations. The bridge, opened in 2005, was the first stainless steel road bridge in Europe.

Material Selection

A reinforced concrete bridge spanned the Algendar River for 30 years but the marine atmosphere led to significant deterioration of the structure. Following settlement of a structural support in one of the abutments, it was decided to replace the bridge. A highly durable material was required for the bridge structure, to achieve a long life with low maintenance requirements. Because of the importance of revenue from tourism for this area, a material which blends in with the natural surroundings and causes minimal disruption during construction was required.

Different grades of carbon steel and stainless steel were considered; Table 1 compares their mechanical properties [1]. The duplex grade 1.4462 (S32205) was eventually selected: it has a high strength (exceeding that of most carbon steels), good ductility and is durable in marine environments.

Following construction, quality control tests were carried out on the bridge structure. These measurements showed that the minimum specified values were exceeded by a significant margin (also shown in Table 1).

Table 1: Mechanical properties of steels considered for the Cala Galdana Bridge

| Type of steel | Yield / 0.2% proof strength (N/mm ²) | Tensile strength (N/mm ²) | Elongation (%) |
|--------------------------------------------------|--------------------------------------------------|---------------------------------------|----------------|
| Carbon (S355) specified | 355 | 510 | 15 |
| Austenitic stainless (1.4404 / S31603) specified | 220 | 530 | 40 |
| Duplex stainless (1.4462 / S32205) specified | 460 | 640 | 25 |
| Duplex stainless (1.4462 / S32205) measured | 535 | 767 | 35 |



Figure 1: General view of the bridge



Figure 2: Arch-longitudinal beam connection

Design

The basis for the bridge design was the draft version of Eurocode 3, Part 1.4 and also other European guidance [2], [3], [4]. Recommendations for the verification of resistance at Ultimate Limit State and limiting criteria for deformation and vibration at Serviceability Limit State were covered by the Spanish code for the design of steel bridges [5].

The two parallel arches that support the bridge span 45 m and rise to a maximum height of 6 m above water level. Bearings fitted into the base of the abutments transmit the horizontal forces into inclined stainless steel struts (and therefore not into the foundations). The arches are joined to two longitudinal beams spanning the full length of the bridge. The bridge thus behaves like a self anchored arch. The longitudinal beams support transverse beams which carry the bridge deck. Composite action between the deck and the transverse beams is achieved by shear connectors welded along the transverse beams.

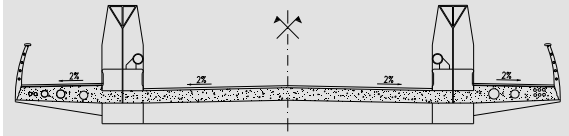

Figure 3: Deck section

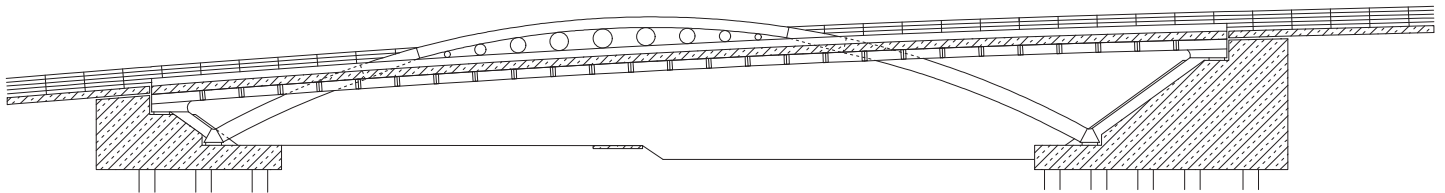

Figure 4: Side elevation of bridge

The arches have a triangular cross-section with a central web and a constant depth of 700 mm over their entire length. However, the width of the section varies between 700-1000 mm. In the central zone of the bridge, the arches rise above the level of the longitudinal beams; throughout this zone a cellular steel plate is connected vertically between the two, so that the cross section resembles a hybrid I beam structure (Figures 5 and 9). This structural form allows direct transfer of the vertical loads in the longitudinal beams (rectangular hollow sections of 1000 x 500 mm with varying thickness) into the arch.

The transverse beams, at 2 m spacings, are rectangular hollow sections 250 mm wide and 500–570 mm variable depth, which enables the deck to achieve a cross-slope of 2%. The thickness of the beam sections varies between 10 and 12 mm. These beams are connected to the longitudinal beams beneath and to the reinforced concrete slab above, which has an average thickness of 300 mm, by means of 20 mm diameter duplex stainless steel shear connectors.



Figure 5: Cellular steel plate between the arch and longitudinal beam

Details of the connection between the arch and strut

In order not to transmit the horizontal component of the axial arch force into the abutments, two inclined struts were designed to connect the base of the arch to the end of the longitudinal beam, anchored at the top of the abutments. The struts are rectangular hollow sections, whose outer dimensions are the same as the longitudinal beams (1000 x 500 mm) with thickness varying between 20 and 25 mm. The struts were internally stiffened in both the longitudinal and transverse directions.

One of the most difficult parts of the bridge to design and construct was the connection between the rectangular inclined strut and the triangular base of the arch. This connection is made by the use of a highly stiffened pot bearing (Figures 6 and 10) which was a natural rubber disk completely enclosed in a steel 'pot' that allows tilting movements around any horizontal axis due to its capacity to deform.



Figure 6: Pot bearing



Figure 7: Pickling paste applied to weld areas to remove contaminants and oxides



Figure 8: Final surface finish on structural members

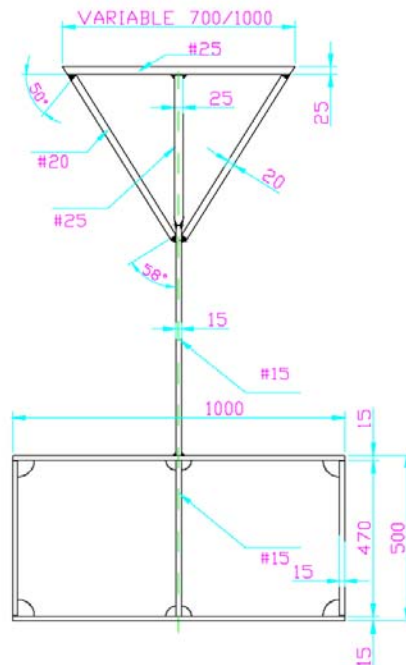

Figure 9: Cross section of arch-beam section

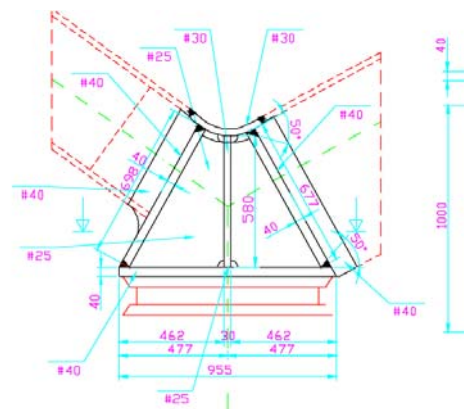

Figure 10: Cross section of the pot bearing

Fabrication and Erection

Fabrication: Cutting and edge preparation of the duplex stainless steel plate was carried out in Sweden, where the plates were produced. The components were assembled in Asturias, Spain. The welding processes used were SMAW inert gas (with covered electrode), MIG, FCAW and SAW, without preheating and not exceeding a temperature of 150°C between two consecutive passes. After welding, all weld areas were pickled to remove the surface contaminants and oxides created during welding. Pickling also encourages the formation of the passive layer that prevents corrosion. Figure 7 shows the steel surface after pickling and Figure 8 shows the final surface following blasting with high pressure glass beads in order to create the required uniform matt surface finish.

Erection: Starting with the demolition of the existing bridge, work on the new bridge began in October 2004 and was finished in June 2005. The main stainless steel structure was assembled on site from 8 sections; each section was lifted onto temporary supports to facilitate welding (Figure 11). Shear connectors were attached by manual welding (Figure 12). All welding was controlled using standard methods (visual inspection, X-ray, magnetic particles, etc).



Figure 11: Temporary supports for the main structure



Figure 12: Shear connectors on transverse beams

Information for this case study was kindly provided by Pedelta.

References and Bibliography

- [1] EN 10088-2:2005 Stainless steels. Technical delivery conditions for sheet/plate and strip of corrosion resisting steels for general purposes
- [2] ENV 1993-1-4:1996 Design of steel structures. Supplementary rules for stainless steel (*now superseded by EN 1993-1-4:2006*)
- [3] Design manual for structural stainless steel (2nd edition), Building Series, Volume 3, Euro Inox and SCI, 2002 (*now superseded by Third Edition, 2006*)
- [4] Structural design of stainless steel, SCI Publication P291, SCI, 2001
- [5] NBE-EA-95 Estructuras de Acero en Edificación

Online Information Centre for Stainless Steel in Construction:
www.stainlessconstruction.com

Procurement Details

| | |
|------------------------------|---------------------------|
| Client: | Consel Insular de Menorca |
| Structural Engineer: | Pedelta |
| Main contractor: | Ferrovial |
| Steelwork contractor: | Ascamon |
| Fabrication yard: | Asturias, Spain |

This series of Structural Stainless Steel Case Studies is sponsored by Team Stainless.

